

16H

Motor Grader



Global Version

Cat® 3406 turbocharged and aftercooled diesel engine

Flywheel horsepower	205 kW	275 hp
Blade width	4877 mm	16 ft

Operating weights (approximate)

On Front wheels	6985 kg	15,400 lb
On Rear wheels	17 763 kg	39,160 lb
Total machine	24 748 kg	54,560 lb

Caterpillar® 16H Motor Grader

The 16H blends productivity and durability to give you the best return on your investment.

Power Train

The 3406C engine offers superior lugging performance, fuel efficiency and reliability. The direct drive, power shift transmission features smooth, on-the-go shifting. To maximize productivity, it has eight forward speeds and eight reverse speeds. **pg. 4-5**

Hydraulics

The load-sensing hydraulic system lowers horsepower consumption and system heat. The control valves provide low lever effort, balanced flow and consistent implement control. Blade float is incorporated into the blade lift valves. **pg. 6**

Drawbar, Circle & Moldboard

The rugged construction of the drawbar, circle and moldboard, and use of replaceable wear inserts provide durability and minimize maintenance costs. For extra protection in this high-impact area, a circle drive slip clutch and blade lift accumulators come standard. **pg. 7**

Matched and balanced components.

The Cat® 3406C engine, power shift transmission and load-sensing hydraulics are designed to work together to deliver top productivity in all applications.

Superior visibility, control layout and operating ease.

The operator is the single most important factor in maintaining high productivity throughout the work day. By offering the best operator's station in the industry, Caterpillar helps operators achieve peak performance.



Operator's Station

Large windows and a tapered engine hood ensure a clear view in all directions. A roomy interior, contour series suspension seat, low-effort controls and low sound levels create a more productive work environment. **pg. 8-9**

Serviceability

All service areas are easily accessible. A modular design permits easy removal of power train components for servicing. **pg. 10**

Environmentally Responsible Design

The engine arrangement is designed to reduce emissions and meet current regulations of the U.S. Environmental Protection Agency, California Air Resources Board and European Union. **pg. 11**



Power Train

Matched Caterpillar components deliver smooth, responsive performance and reliability.

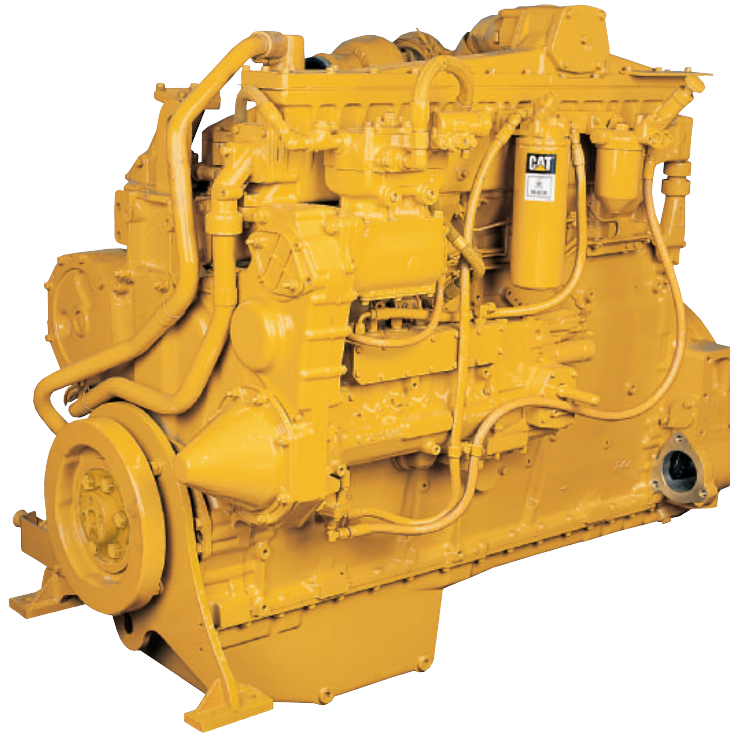

Cat 3406C engine offers superior lugging performance, fuel efficiency and reliability. The six-cylinder engine is turbocharged and aftercooled with a high displacement-to-power ratio. This large displacement produces better lugging capability, lower internal stresses and extended component life.

Superior lugging performance. High torque output and high torque rise make the 3406C engine very responsive. The engine's lugging capability allows it to pull through sudden, short-term increases in loads, reducing the need to downshift. As a result, the operator can maintain desirable working speeds, which means the work gets done faster.

Fuel efficiency. High fuel injection pressures ensure proper mixing of fuel and air. This high injection pressure, coupled with the precise metering and timing of the fuel injection, results in superior fuel efficiency and reduced emissions. High compression ratios ensure dependable cold-starting performance and low emissions.

Extended engine life. The large bore-stroke design and conservative power rating help minimize internal stresses and increase component life. A wide journal crankshaft with a large rod bearing surface significantly increases bearing life.

Ether starting aid comes standard on the 16H to help ensure engine starting in the extreme cold. The system monitors engine coolant temperature to prevent ether from being injected into a hot engine.

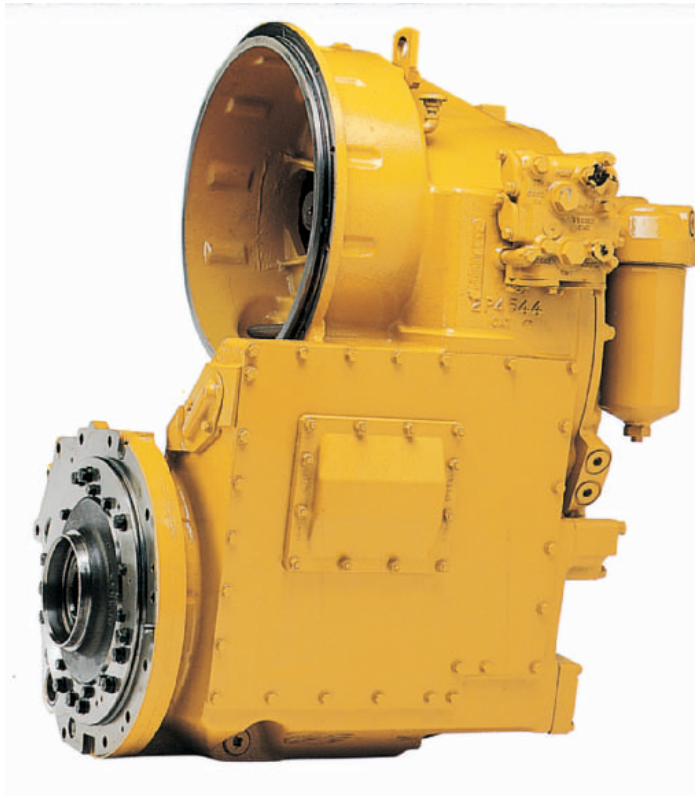

Power shift transmission. Caterpillar designs and builds transmissions specifically for Cat motor graders. The transmission provides on-the-go, full-power shifting as well as inching capability.

Direct drive delivers superior fuel efficiency and better “feel” of blade loads, material hardness and ground speed.

Gear selections. Eight forward speeds and eight reverse speeds give the operator a wide operating range. With four gear selections below 10.6 km/h (6.6 mph), the operator can precisely match working speeds to job conditions for maximum productivity in earthmoving and mining applications. A single lever controls direction, speed and the parking brake.

Planetary design. Large-diameter clutch packs and oil cooling help dissipate heat, resulting in extended transmission life.

Inching capability. Low pedal effort and excellent modulation provide precise control of machine movements when using the inching pedal.

Dual air system supplies braking capacity to each side of the machine. This system ensures secondary braking capability in the event a failure occurs in a single brake line. The dual air system also has a large reserve for stalled-engine braking.

Oil-disc brakes. Caterpillar designs and builds multi-disc brakes that are completely sealed and adjustment-free. The brakes are oil-bathed, air-actuated and spring-released. They are located at each tandem wheel to eliminate braking loads on the power train and to reduce servicing time. The large brake surface provides dependable braking capability and long life before rebuild.

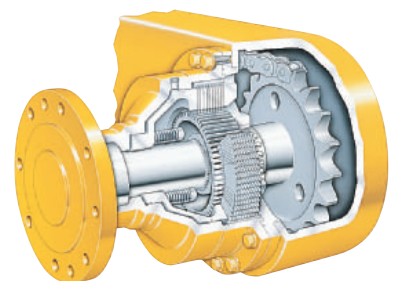

Hydraulics

Balanced hydraulics deliver consistent, precise and responsive control.

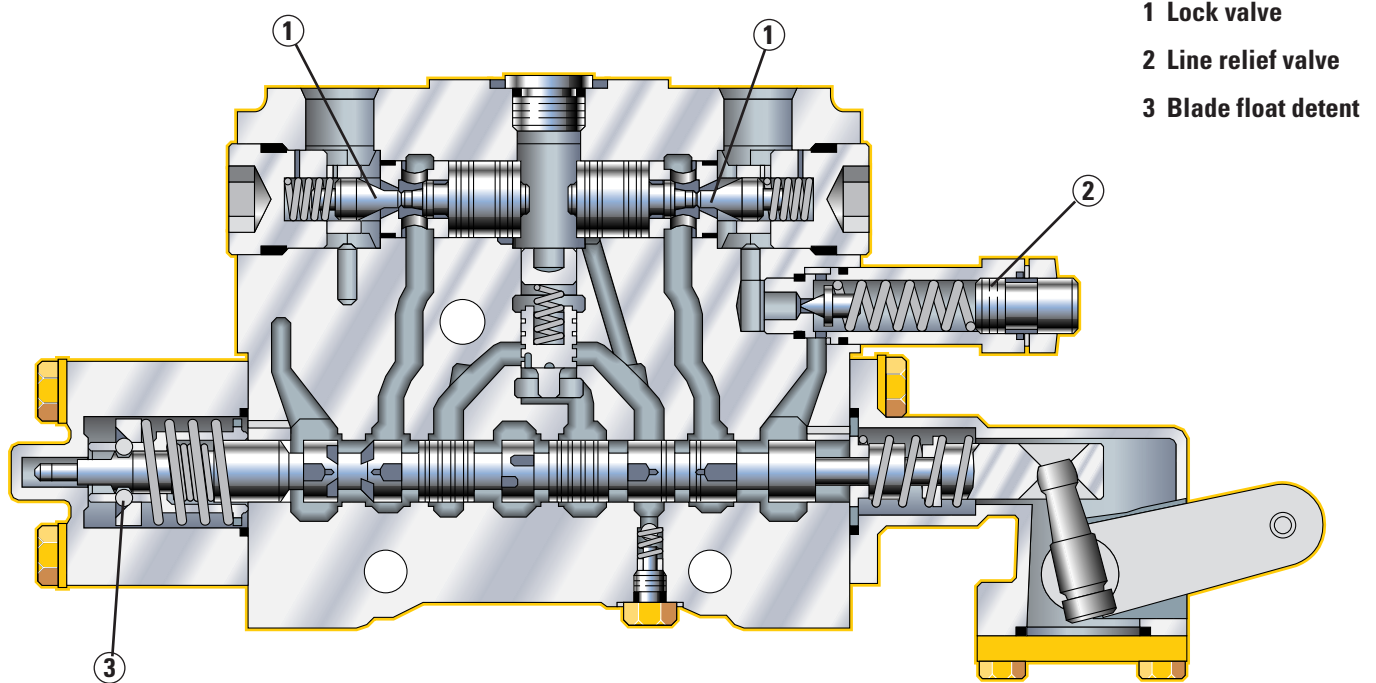

- 1 Lock valve
- 2 Line relief valve
- 3 Blade float detent

Power on demand. Normally, the variable displacement pump idles at near-zero output. When it senses a load requirement, the pump supplies flow and pressure to match the demand. The result is less hydraulic system heat and lower power consumption.

Implement control valves are designed and built by Caterpillar specifically for motor graders. They provide outstanding operator “feel” and predictable system response for unmatched implement control. To help maintain exact blade settings, lock valves are built into all control valves. Line relief valves are also incorporated into selected control valves to protect the cylinders from overpressurization.

Low operator effort. Implement controls are designed to reduce operator fatigue. They feature short lever throws and low efforts in both directions. Properly spaced control levers and short lever throws allow the operator to use multiple controls with one hand.

Balanced flow. When the operator uses several controls at one time, flow is proportioned to ensure all implements can operate simultaneously. If hydraulic demand exceeds pump capacity, cylinder velocities will be reduced by the same ratio.

Blade float is incorporated into the blade lift control valves. Blade float allows the blade to move freely under its own weight. By floating both cylinders, the blade can follow the contours of the road when removing snow. Floating only one cylinder permits the toe of the blade to follow a hard surface while the operator controls the slope with the other lift cylinder.

Large independent oil supply prevents cross-contamination and provides proper oil cooling, which means less heat build-up and extended component life.

Drawbar, Circle & Moldboard

Every component is designed for maximum productivity and durability.

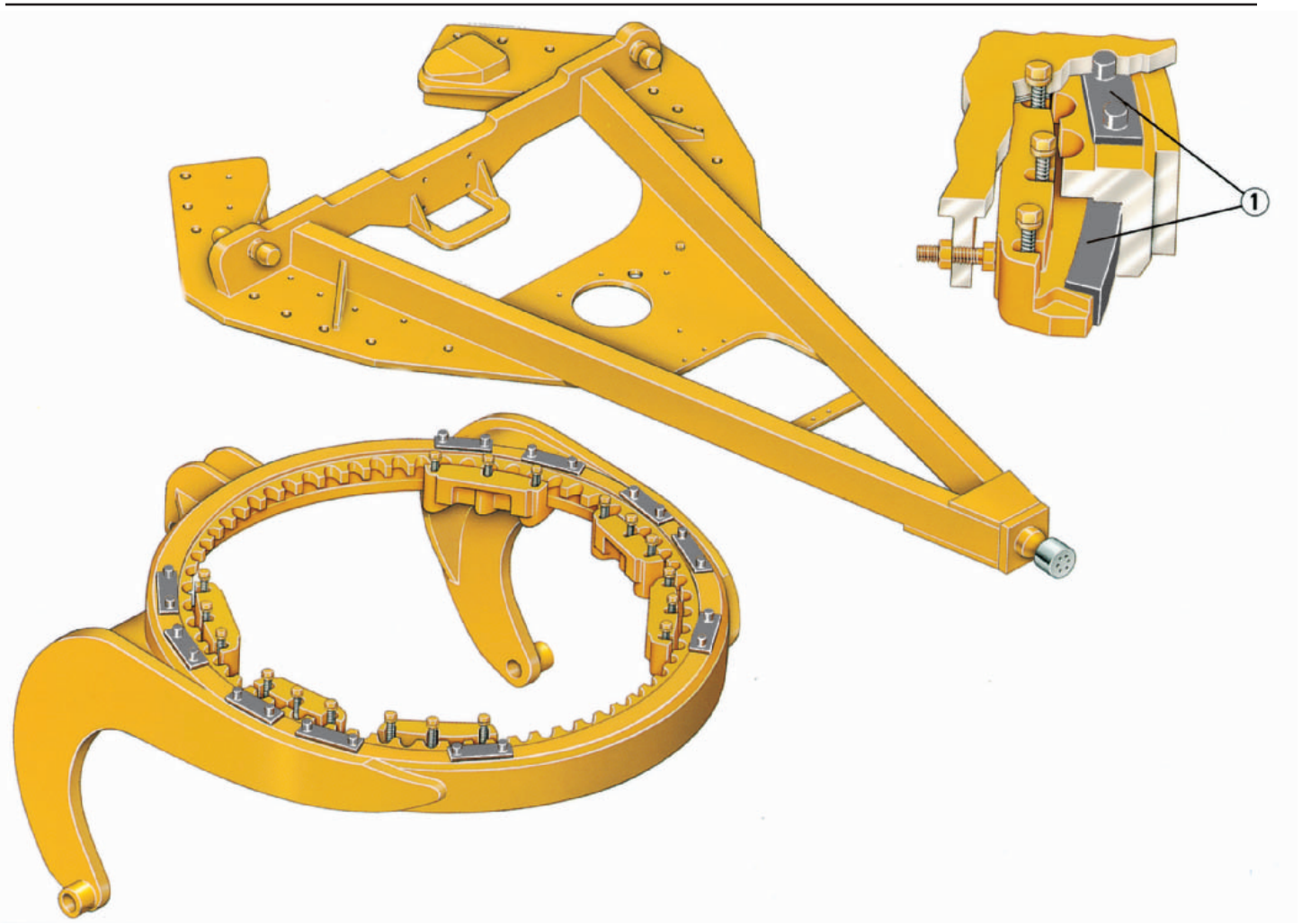

Rugged construction. The drawbar features an A-frame, box-section design for high strength. The bottom is machined to provide accurate adjustment and precise blading. A one-piece forged circle is built to stand up to high stress loads. To resist wear, teeth are induction-hardened in the critical areas. For maximum support, the circle is secured to the drawbar by six support shoes.

Tall moldboard and large throat clearance help move material more quickly and efficiently.

Replaceable wear items. Tough, durable nylon composite wear inserts are located between the drawbar and circle, and between the support shoes and circle. This wear system helps keep components tight for fine grading and allows easy replacement. In addition to providing extended life, these inserts allow higher circle turning forces by reducing the friction between the circle and drawbar. Replaceable metallic wear inserts are used in the blade lift and centershift cylinder sockets, draftball surface, moldboard slide rail and tip bracket bearings.

Circle drive slip clutch protects the drawbar, circle and moldboard from shock when the end of the blade encounters hidden objects. It also reduces the possibility of the grader making abrupt directional changes, further protecting the machine, operator and surroundings.

Blade lift accumulators absorb vertical shocks encountered when the moldboard contacts immovable objects. This system is especially useful in rough grading and rocky areas.

Operator's Station

Caterpillar sets the standard for comfort, convenience and visibility.



Exceptional visibility helps improve operator confidence and productivity in all grader applications. The large front glass area provides an unobstructed view of the moldboard and front tires. The large side windows offer a clear view of the moldboard heel and tandem tires. A wide rear window and tapered engine hood provide good visibility to the rear of the machine, especially to a rear ripper.

Quiet cab. With the doors closed, interior sound level is less than 80 dB(A) when tested using SAE J919 standards. The quiet environment keeps the operator alert and focused.

Low efforts on all pedals, hydraulic controls and the transmission shifter reduce operator strain and fatigue. Pedals are angled and raised off the cab floor to make them easy to reach.

Roomy interior. Extra leg and foot room create a spacious, open cab. The cab includes built-in storage space for personal items such as a lunch box, cooler and coat.

Contour series suspension seat is standard equipment and features fold-up armrests and a retractable seat belt. The seat follows the contours of your body and can be easily adjusted for optimal support and comfort. Seat controls are located in front and to the left of the operator in plain view.

Optional air conditioner and heater arrangements create a comfortable work environment for the operator. Both arrangements use high-capacity systems to ensure the operator stays productive — even in the bitter cold or heat and humidity. They dehumidify the air as well as pressurize the cab, which keeps the air fresh and seals out dust.

The adjustable air vents evenly distribute air throughout the cab, keeping the operator comfortable and the windows clear of fog or frost.

Electronic Monitoring System checks important machine systems and provides the operator with three levels of warning.

Comfort and convenience are designed into every feature:

- Engine start-stop switch enables the operator to start and stop engine with a simple key turn.
- Gauges are located inside the cab, directly in front of the operator.
- Controls and switches are located on the steering console, shift console and right cab post — all within easy reach.
- Rocker switches and transmission shifter are backlit for nighttime operation.
- The operator can adjust implement controls and steering wheel angle independently.
- Cab floor is flush with the bottom of the doors, making it easy to sweep out and keep clean.
- Fresh air filters are located above each cab door for quick replacement.
- Cab door releases from ground level or inside the cab.
- Ashtray, lighter and cupholder are well-positioned for easy access.
- Optional 12-V power port is available for use with computers, cellular phones or other electronic equipment.



Serviceability

Conveniently placed service points make routine maintenance quick and easy.

Easy access to service areas speeds up maintenance and ensures that routine service is performed on time:

- Large hinged doors provide easy access to the engine and radiator service points.
- Spin-on filters make changes quick and clean.
- Lubrication points for the articulation joint are remote-mounted.
- Disconnect switch and most service points are located on the left side, making them easy to access when a snow wing is mounted on the right side of the machine.
- Fuse panel is located inside the cab. Its cover clearly identifies circuits and fuse sizes.
- Tandem oil checkpoint is conveniently located between the wheels in the center of the tandem.
- Service meter is located on the left side of the steering console, giving the operator a clear view from the ground.
- Sampling ports are provided for drawing engine and hydraulic oil.
- Lockable battery box cover is easily removed without tools.

Power train components feature a modular design so you can remove the engine, transmission or final drives independently for quick servicing.

S•O•S oil and coolant sampling valves provide a fast, convenient means of obtaining fluid samples and improve analysis reliability.



XT hose. Caterpillar designs and manufactures its own heavy-duty XT hose and installs it in all high-pressure circuits. Its resistance to abrasion, coupled with its exceptional strength and flexibility, help minimize maintenance and extend life.

O-ring face seals create a reliable seal and are used in all hydraulic circuits to minimize the possibility of oil leaks.

Extended Life Coolant (ELC) extends coolant life to 6000 hours. A single addition of ELC Extender at 3000 hours is the only maintenance required.

Separate wiring harnesses connect all electrical components. This modular harness design provides simple disconnects for major machine repairs or rebuilds. The wires are also color-coded and numbered to speed up diagnosis and repairs. Sure-Seal connectors are made of weather-resistant materials that protect against moisture, corrosion and abrasion.

Environmentally Responsible Design

Caterpillar builds machines that help you create a better world.

The H-Series motor graders respond to important environmental problems such as noise and air pollution. Today's machines run smoother, quieter and cleaner than ever before.

Quiet cab. The sound-suppressed cab has an interior sound level of less than 80 dB(A) when tested using SAE J919 standards.

Quiet machine. On the standard machine, the drive-by exterior sound level will not exceed 80 dB(A) when tested at rated engine speed using SAE J88 standard test. This quiet operation enables the machine to work with minimal disturbance to the surrounding environment.

Low emissions. The engine arrangement meets current regulations of the U.S. Environment Protection Agency, California Air Resources Board and European Union. This engine arrangement reduces the amount of particulates and nitrogen oxides released into the air.

Dry machine. Lubricant fill points and filters are designed to minimize spillage. O-ring face seals, XT hose and Cat hydraulic cylinders protect against leaks.

Ozone protection. To help protect the earth's ozone layer, air-conditioning units use R134a refrigerant, which does not contain chlorofluorocarbons (CFCs).

Complete Customer Support

Caterpillar dealer services help you operate longer with lower costs.

Your Cat dealer offers a wide range of services that can be set up under a customer support agreement when you purchase your equipment. The dealer will help you choose a plan that can cover everything from machine and attachment selection to replacement — to help you get the best return on your investment.

Selection. Make detailed comparisons of the machines you are considering before you buy. How long do components last? What is the cost of preventive maintenance? What is the true cost of lost production? Your Cat dealer can give you precise answers to these questions.

Purchase. Look past initial price. Consider the financing options available as well as day-to-day operating costs and dealer services. Comparative resale value is another item to consider.

Operation. Improving operating techniques can boost your profits. Your Cat dealer has training videotapes, literature and other ideas to help you increase productivity.

Maintenance. More and more equipment buyers are planning for effective maintenance before buying equipment. Choose from your dealer's wide range of maintenance services at the time you purchase your machine. Repair option programs guarantee the cost of repairs up front. Diagnostic programs such as Scheduled Oil Sampling and Technical Analysis help you avoid unscheduled repairs.

Product support. You will find nearly all parts at our dealer parts counter. In the rare case when we don't have a part in stock, we will get it to you fast — usually within 24 hours. Save money with remanufactured parts. You receive the same warranty and reliability as new products at cost savings of 40 to 70 percent.

Replacement. Repair, rebuild or replace? Your Cat dealer can help you evaluate the costs involved so you can make the right choice.

Engine

Four-stroke cycle, six cylinder Caterpillar® 3406 turbocharged and aftercooled diesel engine.

Power ratings

Ratings at 1850 rpm*	kW	hp
Gross power	215	288
Net power	205	275

The following ratings apply at 1850 rpm when tested under the specified standard conditions for the specified standard:

Net power	kW	hp	PS
Caterpillar	205	275	—
ISO 9249	205	275	—
SAE J1349	203	272	—
EEC 80/1269	205	275	—
DIN 70020	—	—	285

Peak torque (net) @ 1200 rpm
1376 Nm 1018 lb-ft

Torque rise 30%

Dimensions

Bore	137 mm	5.40 in
Stroke	165 mm	6.50 in
Displacement	14.6 liters	893 cu in

*Power rating conditions

- based on standard air conditions of 25°C (77°F) and 99 kPA (29.32 in Hg) dry barometer
- used 35° API gravity fuel having an LHV of 42 780 kJ/kg (18,390 Btu/lb) when used at 30°C (86°F) [ref. a fuel density of 838.9 g/L (7.001 lb/U.S. gal)]
- net power advertised is the power available at the flywheel when engine is equipped with fan, air cleaner, muffler and alternator
- no derating required up to 4500 m (14,764 ft) altitude

Features

- direct injection fuel system with individual adjustment-free injection pumps and nozzles
- 3-ring aluminum alloy pistons
- heat-resistant, stellite-faced valves
- forged steel connecting rods
- one-piece cylinder head with 6 hold-down bolts per cylinder
- cast cylinder block with replaceable wet liners
- induction-hardened, forged crankshaft
- direct electric 24-V starting and charging system
- two 12-V, 190 amp-hour, 1300 CCA, low-maintenance batteries
- 50-amp alternator
- tube-type, water-cooled oil cooler
- vertical-flow, steel-fin, tube-type radiator
- dry-type, radial-seal air cleaner with primary and secondary elements

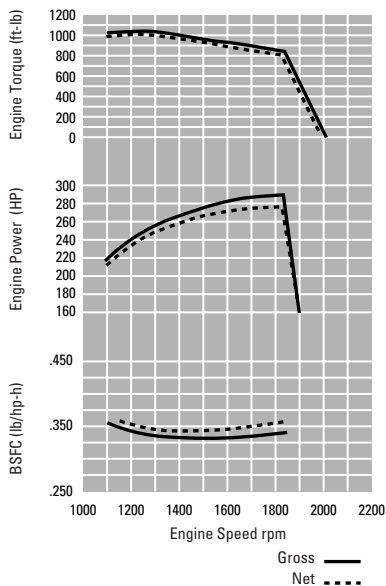

Hydraulic System

Proportional priority pressure compensated system.

Output at 1850 rpm and 24 150 kPa (3500 psi)	243 liters/min	64.1 gpm
Standby pressure	3100 kPa	450 psi
Maximum system pressure	24 150 kPa	3500 psi

Pump features

- load-sensing, pressure-compensating, variable-displacement piston pump
- low standby pressure
- pump supplies only flow and pressure required to move implements plus 2100 kPa (300 psi) margin pressure

Control features

- eight, closed-center control valves standard:
 - right blade lift
 - left blade lift
 - blade sideshift
 - blade tip
 - circle drive
 - centershift
 - front wheel lean
 - articulation

- low effort, short throw controls
- controls spaced to allow use of several controls at once
- blade float position built into each blade lift control valve
- lock valves built into all control valves
- line relief valves for the blade lift, blade tip and blade sideshift circuits are incorporated into the control valves
- if flow requirements exceed pump output, control valves proportion flow to each implement circuit

Other features

- steering circuit given priority over implement circuits
- heavy-duty XT hose
- hose couplings with O-ring face seals
- full-flow filter

Service Refill Capacities

	liters	gallons
Fuel tank	492	130
Cooling system	64	16.6
Crankcase	34	8.8
Transmission, differential and final drives	140	36.4
Tandem housing (each)	121	31.5
Hydraulic system	130	33.8
Hydraulic tank	63	16.4
Circle drive housing	8	2.1
Front wheel spindle bearing housing	.9	.24

Steering

Two-cylinder, hydraulic steering with hand metering unit.

Dimensions

Minimum turning radius (outside front tires)*	8.2 m	27' 0"
Steering range	50° Left/Right	
Articulation angle	20° Left/Right	

*Using front wheel steering, frame articulation, and with differential unlocked.

Features

- large steer stops and steering relief valve help prevent damage when object is hit during full turn
- consistent steering response to the left and right
- optional secondary steering system provides secondary steering capability in event of a complete loss of hydraulic pressure

Transmission

Direct drive, power shift transmission with eight speeds forward.

Maximum travel speeds (at rated rpm with standard 18.00-25 tires)

		km/h	mph
Forward	1	3.9	2.4
	2	5.5	3.4
	3	7.4	4.6
	4	10.7	6.7
	5	16.2	10.1
	6	22.7	14.1
	7	30.8	19.1
	8	44.5	27.7
Reverse	1	3.7	2.3
	2	5.2	3.2
	3	7.0	4.4
	4	10.2	6.3
	5	15.4	9.6
	6	21.6	13.4
	7	29.2	18.2
	8	42.3	26.3

Features

- single lever controls direction, speed and parking brake
- inching pedal
- low efforts on shift lever and inching pedal
- neutral start switch prevents engine from starting if transmission is engaged

Frame

Flanged, box-section design.

Dimensions

Front frame	mm	in
-------------	----	----

Top and bottom plates

Width	356	14
Thickness	29	1.14

Side plates

Width	324	12.75
Thickness	14	.55

Linear weights

Front frame	kg/m	lb/ft
-------------	------	-------

Minimum	231	155
Maximum	301	202

Section modulus

Front frame	cm ³	in ³
-------------	-----------------	-----------------

Minimum	3746	228
Maximum	8057	491

Features

- single piece top and bottom plates run from bolster to articulation joint
- rear frame has two box-sectioned channels integral with fully welded differential case

Front Axle

Live spindle design.

Dimensions

Front axle		
------------	--	--

Ground clearance	660 mm	26"
Front wheel lean		18°
Oscillation angle		32°

Features

- allows use of large outboard bearings for high load-carrying capability of the wheel assembly
- wheel spindle rotates inside sealed compartment
- bearings bathed in oil

Tandems

Dimensions

	mm	in
--	----	----

Height	648	25.51
Width	236	9.29

Sidewall thickness

Inner	22	.87
Outer	22	.87
Drive chain pitch	63	2.50
Wheel axle spacing	1840	72.00
Tandem oscillation	15° Forward	25° Reverse

Brakes

Meets the following standards: SAE J1473 OCT 90 and ISO 3450-1996.

Service brake features

- air-actuated, oil-disc brakes located in each of the four wheel spindle housings
- sealed and adjustment-free
- lubricated and cooled by tandem housing oil
- 42 209 cm² (6544 in²) of total braking surface

Parking brake features

- multiple oil-disc unit
- located in the transmission on the output shaft
- manually actuated
- spring-engaged, air pressure-released
- engaged parking brake neutralizes transmission
- 2058 cm² (319 in²) of total brake surface area

Secondary brake features

- separate circuits to right and left tandems
- malfunction of one circuit still leaves machine with at least half of original braking capacity
- dual chamber air tank provides air to actuate brakes five times after engine and compressor stop
- in the event of total braking loss, the spring-actuated parking/emergency brake can be used to lock the wheels on any surface

Tires and Rims

Tires	Rims	Type
-------	------	------

18.00-25	13" x 25"	MP
23.5-25	19.5" x 25"	MP

MP = Multi-Piece Rim

Notes: An assortment of bias and radial tire models are available from various manufacturers offering different sizes, strength indexes and industry types.

Dependent on the weight of additional equipment, the machine load may exceed certain tire capabilities. Caterpillar recommends that you carefully evaluate all conditions before selecting a tire model.

Drawbar

Box-section, A-frame design.

Dimensions

Drawbar frame	mm	in
Height	165	6.5
Thickness	89	3.5

Features

- yoke plate completely covers top of circle
- six shoes support circle
- all shoes have vertical and horizontal adjustment
- 10 replaceable nylon composite wear strips between circle and drawbar
- six replaceable nylon composite wear strips between the circle and support shoes

Circle

Single-piece, rolled ring forging.

Dimensions

Circle	mm	in
Circle diameter	1822	71.75
Blade beam thickness	50	1.97

Features

- 64 uniformly spaced, flame-cut teeth
- teeth surfaces hardened on front 240° of circle
- raised wear surfaces, top and bottom
- hydraulically driven, circle drive motor
- 360° circle rotation
- circle drive slip clutch protects circle, drawbar, and moldboard when objects hit near toe or heel of moldboard

Moldboard

Fabricated from wear-resistant, high-carbon steel.

Dimensions

Moldboard	mm	in
Length	4877	192
Height	787	31
Thickness	25	1
Arc radius	413	16.25
Throat clearance	122	4.8

Cutting edge	mm	in
Width	203	8
Thickness	25	1

End bit	mm	in
Width	152	6
Thickness	19	.75

Features

- heat-treated sideshift rails
- replaceable metallic wear inserts
- cutting edge and end bit are Caterpillar through-hardened, curved DH-2 steel
- 19 mm (.75") diameter bolts
- blade lift accumulators protect circle, drawbar, and moldboard from vertical shocks
- three sideshift mounting locations

Blade Range

Full range of blade positioning.

		mm	in
Circle centershift	Right	560	22.0
	Left	690	27.2
Moldboard sideshift	Right	790	31.1
	Left	650	25.6
Maximum shoulder reach outside of tires	Right	2311	91.0
	Left	2311	91.0
Maximum lift above ground		419	16.5
Maximum depth of cut		470	18.5
Blade tip range			40° Forward
			5° Backward

Dimensions

All dimensions are approximate.

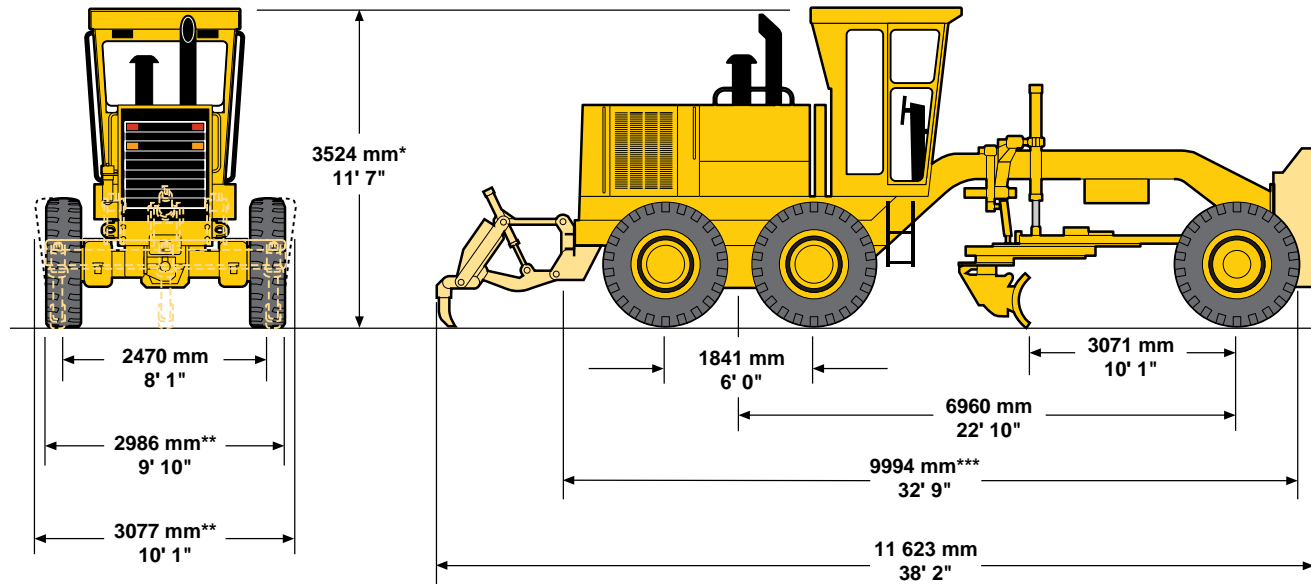

Operating weights (approximate)

on front wheels	6985 kg	15,400 lb
on rear wheels	17 763 kg	39,160 lb
total machine	24 748 kg	54,560 lb

- * add 225 mm (8.9") for optional full height cab
- ** add 286 mm (11.3") for optional 23.5-25 tires
- *** add 155 mm (6.1") for front push plate
add 1475 mm (4" 10") for rear-mounted ripper-scarifier

Dimension and operating weights based on standard machine configuration with 18.00-25 12PR (E-2) tires, full fuel tank, coolant, lubricants and operator.

Ripper

Type	Ripper (rear-mounted)	
	Working width	2980 mm
Ripping depth, maximum	452 mm	17.8"
Ripper shank holders:		
number		7
spacing	445-500 mm	17.5-20"
Increase in machine length, beam raised	1610 mm	63.4"
Penetration force*	10 163 kg	22,410 lb
Pryout force	15 323 kg	33,788 lb

*Varies with machine configuration

Cab with ROPS/FOPS

Caterpillar cab and Rollover Protective Structure (ROPS) are standard.

Cab features

- 80 dB(A) operator sound pressure level when measured per SAE J919 at rated speed
- low profile, sound-suppressed cab is standard
- optional full height, sound-suppressed cab
- engine key start/shutoff switch
- back-lit rocker switches
- adjustable control console
- tilt adjustable steering wheel
- cloth-covered, contour suspension seat with multiple adjustments
- retractable seat belt
- fuse panel in steering control console
- optional 24-V to 12-V 25-amp converter
- optional heater/air conditioner systems with adjustable vents and three-speed fan
- optional defroster fans
- gauges located in the cab
 - fuel
 - voltmeter
 - brake air pressure, two
 - engine coolant temperature
 - articulation
- service hour meter on steering console

- EMS operator warning system
- wipers and washers, windshield and lower front windows
- optional rear wiper and washer
- optional rear window sunshade
- fixed lower front windows
- optional opening lower front windows
- optional sliding side windows
- 10° slanted rear window
- low effort, suspended foot pedals
- sweep-out cab floor
- ground-level door release
- lunch box location
- cupholder
- ashtray and 24-V lighter
- optional 12-V power port
- coat hanger
- location and wiring for two-way or entertainment radio

Note:

When properly installed and maintained, the Caterpillar cab, when tested with doors and windows closed according to ANSI/SAE J1166 MAY90, meets OSHA and MSHA requirements for operator sound exposure limits in effect at time of manufacture.

ROPS/FOPS features

- ROPS (Rollover Protective Structure) meets the following criteria:
 - SAE J396
 - SAE J1040 MAY94
 - ISO 3471-1994
- also meets the following FOPS (Falling Object Protective Structure) criteria:
 - SAE J231 JAN81
 - ISO 3449-1992

Functions analyzed by Electronic Monitoring System (EMS)

- **Category I** — Flashing indicator for alternator problem and parking brake engagement.
- **Category II** — Flashing action lamp and indicator for engine coolant and hydraulic oil heating problem and transmission electrical problem. Requires change in machine operation.
- **Category III** — Loud action alarm, plus flashing action lamp and indicator to signal problem with engine oil pressure, brake air pressure, supplemental steering, also parking brake applied with transmission engaged. Requires immediate machine shutdown.

Standard Equipment

Standard and optional equipment may vary. Consult your Caterpillar dealer for details.

Electrical

- Alarm, back up
- Alternator, 50-amp, sealed
- Batteries, two low-maintenance, 1300 CCA
- Battery box cover, lockable
- Electrical system, 24-V
- Lights, stop and tail
- Motor, starting

Operator Environment

- Accelerator-decelerator
- Ashtray and lighter
- Coat hook
- Control console, adjustable
- Cupholder
- EMS, operator warning system
- Gauges inside the cab
 - articulation
 - engine coolant temperature
 - fuel
 - voltmeter
 - brake air pressure, two
- Hydraulic controls, load-sensing
 - articulation
 - blade lift, right and left with float position
 - blade sideshift
 - blade tip
 - centershift
 - circle drive
 - front wheel lean

- Mirror, wide angle, inside rearview
- Power steering, hydraulic
- ROPS cab, sound-suppressed, 80 dB(A), low profile
- Seat, cloth-covered, contour suspension
- Seat belt, retractable, 3"
- Service hour meter
- Steering wheel, tilt adjustable
- Storage area, cooler/lunch box
- Throttle, hand
- Wipers and washers, windshield and lower front windows
- Washers and wipers, lower front windows
- Windows, fixed lower front

Power Train

- Accumulators, blade lift
- Air cleaner, dry type, radial seal with service indicator
- Blower fan
- Brakes, oil-disc, four-wheel, air actuated
- Differential, lock-unlock
- Engine, 3406 DITA diesel, low emissions
- Muffler, under hood
- Oil change system
- Parking brake, multi-disc, sealed and oil-cooled
- Precleaner, automatic dust ejector
- Prescreener
- Priming pump, fuel
- Tandem drive
- Transmission, 8-speed forward and 8-speed reverse power shift, direct drive with electronic shift control and overspeed protection

Other Standard Equipment

- Bumper, rear, with hitch
- Cap locks for hydraulic tank, radiator access cover and fuel tank, with locks
- Circle drive slip clutch
- Cutting edges, 203 mm x 25 mm (8" x 1") curved DH-2 steel
- Doors, engine compartment, with locks
- Drawbar, six shoe with replaceable nylon composite wear strips
- End bits, 19 mm (3/4") DH-2 steel
- Ether starting aid
- Frame, articulated, with safety lock
- Fuel tank, 492-liter (130-gallon)
- Horn, air
- Moldboard, 4877 mm x 787 mm x 25 mm (16' x 31" x 1")
- Rims, refer to Tires and Rims section, page 14
- S•O•S ports, engine and hydraulic
- Tires, refer to Tires and Rims section, page 14
- Tool box, with lock

Optional Equipment

With approximate change in operating weight.

	kg	lb		kg	lb
Air conditioner with heater and pressurizer	92	202	Mirrors, dual inside	—	—
Air dryer	15	32	Mirrors, outside mounted	8	18
Alternator, 75-amp	11	25	Power port, 12-V	2	5
Alternator, 100-amp	16	35	Push plate, front mounted	587	1292
Cab, ROPS, high profile, sound-suppressed	77	170	Radio ready, entertainment	—	—
Canopy, ROPS, high profile, with rear wall and window	-41	-90	Rims, refer to Tires and Rims section, page 14		
Converter, 25-amp, 24-V to 12-V	5	11	Ripper, rear mounted	1951	4298
Cutting edges, 254 mm x 25 mm (10" x 1")	59	130	Ripper, shank/tooth, one	60	132
Fan, defroster, front and rear	2	4	Seat, vinyl-covered, contour suspension	—	—
Fuel system, fast fill	11	25	Steering system, secondary	52	114
Graderbit system, standard bit type	114	250	Sunshade, rear window	3	7
Guard, transmission	98	215	Tachograph drive	11	24
Heater, engine coolant	2	4	Tires, refer to Tires and Rims section, page 14		
Heater, with pressurizer	35	76	Windows, lower front, opening	3	6
Hydraulic arrangements with additional hydraulic valve for rear ripper	7	16	Windows, sliding side	4	8
Instrument panel cover, canopy	4	10	Wiper and washer, rear	7	16
Lighting systems:					
bar mounted lights, directional and headlights	20	45			
cab mounted lights, directional and headlights	9	20			
cab and bar mounted lights, directional headlights and work lights	21	47			
work lights, front and rear	6	13			
warning light, cab or canopy mounted	3	6			

16H Motor Grader

AEHQ5272 (10-98)
(Replaces AEHQ5028-01)

www.CAT.com

© 1998 Caterpillar
Printed in U.S.A.

Materials and specifications are subject to change without notice.
Featured machines in photos may include additional equipment.
See your Caterpillar dealer for available options.

CATERPILLAR[®]