



Volvo Construction Equipment

EC210D

Volvo Excavators 20.5-23.8 t 167 hp



The power to perform

Get the most out of your excavator in any application. The EC210D is equipped with a range of features to ensure a superior performance, shift after shift. Designed with Volvo's extensive experience and expertise, this robust machine delivers ultimate productivity and efficient operation in a wide variety of tasks.

Powerful Volvo engine

Experience optimum power with the EC210D's robust Volvo engine. Working together with the machine's proven hydraulics, this engine delivers high torque at low rpm for the ultimate combination of performance and improved fuel efficiency.



Enhanced operator performance

Operate in comfort for a more productive work shift. The EC210D is equipped with a spacious and safe operator environment offering enhanced all-around visibility, an adjustable seat and ergonomic controls. The improved cab interior features a new I-ECU monitor that displays a range of information for efficient operation.



Excellent controllability

The EC210D features increased hydraulic flow for responsive, accurate control in grading and combined operations. Benefit from smoother and easier movement when traveling and lifting simultaneously as well as better grading quality from the harmonized boom and arm movement.



Efficient work mode

For fast cycle times and optimum fuel consumption, the EC210D is equipped with the new G4 work mode. Operators can choose the best mode to suit the task at hand, selecting from I (Idle), F (Fine), G (General), H (Heavy) and P (Power max) mode. Choose the correct mode according to your working conditions for added versatility and increased productivity.





GET MORE DONE

The EC210D is built to help you do more. This excavator delivers a strong, versatile performance in a wide range of applications. A robust frame combines with optimal engine power and hydraulic pressure to provide superior digging forces and fast cycle times for excellent productivity in all operations.



OUTSTANDING FUEL EFFICIENCY

Reduce fuel consumption and increase productivity with the EC210D. The powerful engine works in harmony with the optimized hydraulic system in combination with auto-idle function to deliver outstanding fuel efficiency.

Efficiency that lasts

The Volvo EC210D is a versatile machine that ensures optimum profitability. This excavator is designed to lower fuel consumption and reduce operating costs, featuring best-in-class fuel efficiency and Volvo's intelligent ECO mode. Excellent service access and a durable design guarantee a long machine life and allow you to get the most out of your machine.

ECO mode

Work efficiently and profitably with Volvo's intelligent ECO mode. This feature contributes to the machine's total improved fuel efficiency – without any loss of performance. The design optimizes flow and pressure while maintaining digging power and swing torque.

Easy to service

The EC210D is built to ensure servicing is safe, quick and easy, featuring anti-slip plates, grouped filters, ground-level service access and centralized lubrication points. Long service intervals enhance machine availability and increase uptime for maximum productivity.



Superior durability

Benefit from a robust performance, shift after shift. Built with durable components for outstanding results in all applications, the EC210D is designed to secure lasting machine value and an excellent return on investment.



Volvo versatility

Make sure you are ready to tackle any job. Volvo CE offers a comprehensive range of attachments that let you handle a wide variety of tasks. The EC210D can be fitted with a selection of buckets and breakers that work in harmony with the machine to ensure optimal performance and profitability in any application.

Quality Volvo buckets

Volvo offers a range of high quality buckets designed to perform efficiently in a variety of materials. Featuring exceptional design and built-in durability, these buckets are equipped with Volvo teeth to handle the toughest applications.



Powerful breakers

The EC210D can be equipped with either a top or side mounted Volvo hydraulic breaker built to break even most demanding materials. With consistent power and high breaking force you'll benefit from maximum impact and durability. Set your Volvo breaker at the right frequency to suit your application needs.



Attachment Management System

Pre-set and adjust hydraulic flow from the monitor inside the cab with this password-protected management system, providing storage for up to 20 different attachments for increased versatility. You can choose between one or two pump flow to maximize profits and productivity.



Optional auxiliary piping

The Volvo-designed hydraulic breaker / shear piping and quick coupler piping option provides optimum flow to the hydraulic attachments. State-of-the-art auxiliary lines allow the correct flow and pressure for special attachments.





A VERSATILE MACHINE

Access more applications and efficiently perform a variety of tasks with Volvo's extensive attachment range. The EC210D is compatible with a selection of robust buckets, breakers and piping options that allow you to adapt to any job with ease. All attachment options ensure a quality performance, high productivity and fast cycle times.



CUSTOMER SUPPORT AGREEMENTS

The range of Customer Support Agreements offer preventive maintenance, total repairs and a number of uptime services. Volvo uses the latest technology to monitor machine operation and status, giving you advice to increase your profitability. By having a Customer Support Agreement you are in control of your service costs.

Adding value to your business

Being a Volvo customer means having a complete set of services at your fingertips. Volvo can offer you a long-term partnership, protect your revenue and provide a full range of customer solutions using high quality parts, delivered by passionate people. Volvo is committed to increasing the positive return on your investment and maximising uptime.

Complete Solutions

Volvo has the right solution for you. So why not let us provide all your needs throughout the whole life cycle of your machine? By listening to your requirements, we can reduce your total cost of ownership and increase your revenue.



Genuine Volvo Parts

Our attention to detail is what makes us stand out. This proven concept acts as a solid investment in your machine's future. Parts are extensively tested and approved because every part is vital for uptime and performance. Only by using Genuine Volvo Parts, can you be sure that your machine retains the renowned Volvo quality.



Service Network

In order to respond to your needs faster, a Volvo expert is on the way to your job site from one of our Volvo facilities. With our extensive infrastructure of technicians, workshops and dealers, Volvo has a comprehensive network to fully support you using local knowledge and global experience.



CareTrack

CareTrack is the state-of-the-art Volvo telematics system that provides access to a wide range of machine monitoring information designed to save time and money. Proactively manage service and maintenance schedules, optimize machine and operator performance and reduce fuel costs with CareTrack.



A profitable performance

ECO mode

Volvo's intelligent ECO mode increases fuel efficiency without any loss of performance.

FUEL EFFICIENCY

The powerful engine works in harmony with optimized hydraulics and auto-idle function for outstanding fuel efficiency.

Optional auxiliary piping

The EC210D can be adjusted to take a variety of hydraulic lines, fitted with breaker and shear piping (X1).

Excellent controllability

Increased hydraulic flow ensures responsive, accurate control in grading and combined operations.

A VERSATILE MACHINE

The EC210D is compatible with a range of robust buckets, breakers and piping options so you can adapt to any job.

Efficient work mode

For fast cycle times and optimum fuel consumption, the EC210D is equipped with the new G4 work mode.



Superior durability

Built with durable components for outstanding results in all applications, the EC210D secures lasting machine value.

Enhanced operator performance

A spacious, comfortable operator environment offers enhanced all-around visibility and a new I-ECU monitor.

GET MORE DONE

A robust frame, powerful engine and optimum hydraulic pressure provide superior digging forces and fast cycle times.

Powerful Volvo engine

A robust Volvo engine delivers high torque at low rpm for the ultimate combination of performance and fuel efficiency.



CUSTOMER SUPPORT AGREEMENTS

Customer Support Agreements offer preventive maintenance, total repairs and a number of uptime services.

Easy to service

Ground-level service access, centralized lubrication points and anti-slip plates make services quick and easy.

Volvo EC210D in detail

Engine

The engine, which provide excellent performance, is equipped with four cylinder, vertical, electronic-controlled high pressure fuel injectors, turbo charger with waste gate, air-to-air intercooler and water cooled diesel type.

Engine	Volvo	D5E
Max power at	r/min	2 000
Net, ISO 9249/SAE J1349	kW	115
	hp	156
Gross, ISO 14396/SAE J1995	kW	123
	hp	167
Max torque	Nm	670
at engine speed	r/min	1 600
No. of cylinders		4
Displacement	l	4.7
Bore	mm	108
Stroke	mm	130

Electrical System

Well protected high-capacity electrical system. Waterproof double-lock connectors are used to ensure corrosion-free connection. Main relays and fuses are located in a shielded electrical distribution box. The master switch is standard. Advanced monitoring of machine functions and important diagnostic information is displayed on the I-ECU.

Voltage	V	24
Batteries	V	2 x 12
Battery capacity	Ah	150
Alternator	V/Ah	28/80
Start motor	V - kW	24 - 5.5

Swing System

The swing system uses an axial piston motors, driving a planetary gearbox for maximum torque. An automatic holding brake and anti-rebound valve are standard.

Max. slew speed	r/min	12.3
Max. slew torque	kNm	76.7

Drive

Each track is powered by an automatic two-speed shift travel motor. The track brakes are multi-disc, spring-applied and hydraulic released. The travel motor, brake and planetary gears are well protected within the track frame.

Max. drawbar pull	kN	183
Max. travel speed (low)	km/h	3.6
Max. travel speed (high)	km/h	5.8
Gradeability	°	35

Undercarriage

Robust X-shaped frame with greased and sealed track chains as standard.

EC210D

Track shoe		2 x 46
Link pitch	mm	190
Shoe width, triple grouser	mm	600 / 700 / 800 / 900
Shoe width, triple grouser (HD)	mm	600
Bottom rollers		2 x 7
Top roller		2 x 2

EC210DL

Track shoe		2 x 49
Link pitch	mm	190
Shoe width, triple grouser	mm	500 / 600 / 700 / 800 / 900
Shoe width, triple grouser (HD)	mm	600
Shoe width, double grouser	mm	700
Bottom rollers		2 x 8
Top roller		2 x 2

EC210DLR

Track shoe		2 x 49
Link pitch	mm	190
Shoe width, triple grouser	mm	800 / 900
Bottom rollers		2 x 8
Top roller		2 x 2

Hydraulic system

The hydraulic system and MCV (main control valve) use intelligent technology to control on-demand flow for high productivity, high-digging capacity and excellent fuel economy.

The summation system, boom, arm and swing priority along with boom and arm regeneration provides optimum performance.

The following important functions are included in the system: Summation system: Combines the flow of both hydraulic pumps to ensure quick cycle times and high productivity

Boom priority: Gives priority to the boom operation for faster raising when loading or performing deep excavations.

Arm priority: Gives priority to the arm operation for faster cycle times in leveling and for increased bucket filling when digging.

Swing priority: Gives priority to swing functions for faster simultaneous operations.

Regeneration system: Prevents cavitation and provides flow to other movements during simultaneous operations for maximum productivity.

Power boost: All digging and lifting forces are increased.

Holding valves: Boom and arm holding valves prevent the digging equipment from creeping.

Main pump. 2 x variable displacement axial piston pumps

Maximum flow	l/min	2 x 212
--------------	-------	---------

Pilot pump. Gear pump

Maximum flow	l/min	1 x 18
--------------	-------	--------

Relief valve setting pressure

Implement	MPa	32.4 / 34.3
-----------	-----	-------------

Travel circuit	MPa	34.3
----------------	-----	------

Slew circuit	MPa	27.9
--------------	-----	------

Pilot circuit	MPa	3.9
---------------	-----	-----

Hydraulic Cylinders

Mono boom		2
-----------	--	---

Bore x Stroke	ø x mm	125 x 1 235
---------------	--------	-------------

Arm		1
-----	--	---

Bore x Stroke	ø x mm	135 x 1 540
---------------	--------	-------------

Bucket		1
--------	--	---

Bore x Stroke	ø x mm	120 x 1 065
---------------	--------	-------------

LR Bucket		1
-----------	--	---

Bore x Stroke	ø x mm	100 x 865
---------------	--------	-----------

Service Refill

Fuel tank	l	375
-----------	---	-----

Hydraulic system, total	l	300
-------------------------	---	-----

Hydraulic tank	l	160
----------------	---	-----

Engine oil	l	17
------------	---	----

Engine coolant	l	15
----------------	---	----

Slew reduction unit	l	8.6
---------------------	---	-----

Travel reduction unit	l	2 x 5.8
-----------------------	---	---------

Cab

The Volvo cab features a brand new Volvo styling including a strong cab structure, slim pillars and a large glass area for good visibility, a spacious cab, an ergonomic switch layout, efficient air ventilation and a pressurized cab.

Sound Level

Sound level in cab according to ISO 6396

LpA (standard)	dB(A)	73
----------------	-------	----

LpA (tropical)	dB(A)	73.5
----------------	-------	------

External sound level according to ISO 6395 and EU Noise Directive (2000/14/EC)

LwA (standard)	dB(A)	102.5
----------------	-------	-------

LwA (tropical)	dB(A)	103.5
----------------	-------	-------

Specifications

MACHINE WEIGHTS AND GROUND PRESSURE

Description	Shoe width	Operating weight	Ground pressure	Overall width	Operating weight	Ground pressure	Overall width
Units	mm	kg	kPa	mm	kg	kPa	mm
		EC210D, 5.7m boom, 2.9m arm, 0.92m³ / 870kg bucket, 3 700kg counterweight			EC210D, 5.7m boom, 2.9m arm, 0.92m³ / 870kg bucket, 4 200kg counterweight		
Triple grouser	600	20 670	46.2	2 800	21 170	47.4	2 800
	700	20 830	39.9	2 900	21 330	40.9	2 900
	800	21 260	35.7	3 000	21 600	36.2	3 000
	900	21 960	32.8	3 100	21 870	32.6	3 100
Triple grouser, HD	600	22 920	51.3	2 800	22 130	49.5	2 800
		EC210DL, 5.7m boom, 2.9m arm, 0.92m³ / 870kg bucket, 3 700kg counterweight			EC210DL, 5.7m boom, 2.9m arm, 0.92m³ / 870kg bucket, 4 200kg counterweight		
Triple grouser	500	20 890	52	2 890	21 390	53.2	2 890
	600	21 150	43.8	2 990	21 650	44.9	2 990
	700	21 320	37.9	3 090	21 820	38.8	3 090
	800	21 610	33.6	3 190	22 110	34.4	3 190
	900	21 900	30.3	3 290	22 400	31	3 290
Triple grouser, HD	600	22 180	46	2 990	22 680	47	2 990
Double grouser	700	21 890	38.9	3 090	22 390	39.8	3 090
		EC210DLR, 8.85m boom, 6.25m arm, 0.52m³ / 460kg bucket, 4 900kg counterweight					
Triple grouser	800	23 290	36.2	3 190			
	900	23 570	32.6	3 290			

BUCKET SELECTION GUIDE

Bucket type		Capacity	Cutting width	Weight	Teeth	EC210D				EC210DL			
						5.7m boom		5.7m boom		5.7m boom		5.7m boom	
						600mm shoe, 3 700kg counterweight		600mm shoe, 4 200kg counterweight		600mm shoe, 3 700kg counterweight		600mm shoe, 4 200kg counterweight	
						2.5m arm	2.9m arm	2.5m arm	2.9m arm	2.5m arm	2.9m arm	2.5m arm	2.9m arm
		m ³	mm	kg	EA								
Direct fit Buckets	General purpose	0.92	1 145	862	5	C	C	C	C	C	C	C	C
		0.92	1 145	870	5	C	C	C	C	C	C	C	C
		1.00	1 210	884	5	C	B	C	C	C	C	C	C
		1.00	1 210	895	6	C	B	C	C	C	C	C	C

Please consult with your Volvo dealer for the proper match of buckets and attachments to suit the application.

The recommendations are given as a guide only, based on typical operation conditions.

Bucket capacity based on ISO 7451, heaped material with a 1:1 angle of repose.

Maximum material density

Maximum material density

A	1 200~1 300 kg/m ³	Coal, Caliche, Shale
B	1 400~1 600 kg/m ³	Wet earth and clay, Limestone, Sandstone
C	1 700~1 800 kg/m ³	Granite, Wet sand, Well blasted rock
D	1 900 kg/m ³ ~	Wet mud, Iron ore

X : Not recommended

Specifications

DIMENSIONS

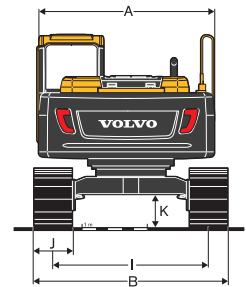
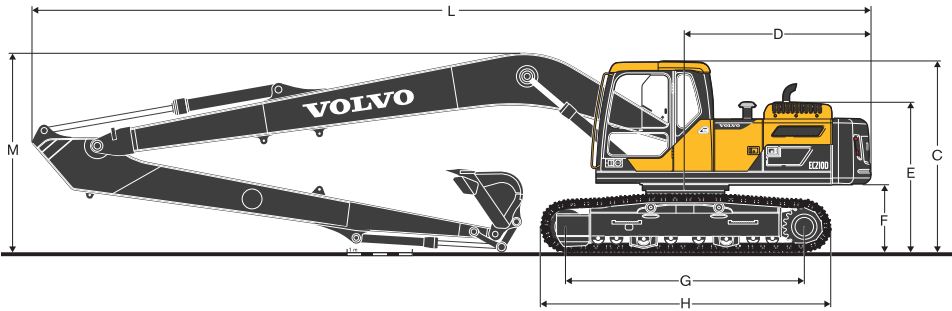
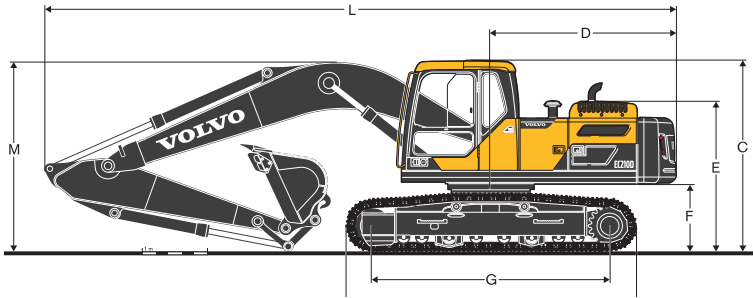

Description	Unit	EC210D		EC210DL		EC210DLR
Boom	m	5.7	5.7	5.7	5.7	8.85
Arm	m	2.5	2.9	2.5	2.9	6.25
A Overall width of upper structure	mm	2 700	2 700	2 700	2 700	2 700
B Overall width	mm	2 800	2 800	2 990	2 800	3 190
C Overall height of cab	mm	2 930	2 930	2 930	2 930	2 930
D Tail swing radius	mm	2 850	2 850	2 850	2 850	2 850
E Overall height of engine hood	mm	2 315	2 315	2 315	2 315	2 315
F Counterweight clearance*	mm	1 025	1 025	1 025	1 025	1 025
G Tumbler length	mm	3 370	3 370	3 660	3 370	3 660
H Track length	mm	4 160	4 160	4 460	4 160	4 460
I Track gauge	mm	2 200	2 200	2 390	2 200	2 390
J Shoe width	mm	600	600	600	600	800
K Min. ground clearance*	mm	460	460	460	460	460
L Overall length	mm	9 745	9 690	9 745	9 690	12 880
M Overall height of boom	mm	3 080	2 940	3 080	2 940	3 055

* Without shoe grouser

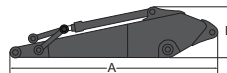
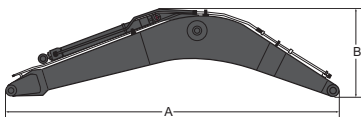

Description	Unit	Mono Boom	Long Reach	Description	Unit	2.5	2.9	Long Reach
Boom	m	5.7	8.85	Arm	m	2.5	2.9	6.25
A Length	mm	5 910	9 060	A Length	mm	3 525	3 910	7 330
B Height	mm	1 585	1 460	B Height	mm	860	860	945
Width	mm	670	670	Width	mm	440	440	385
Weight	kg	2 055	2 510	Weight	kg	1 129	1 130	1 309

Includes cylinder, piping and pin, excludes boom cylinder pin

* Includes bucket cylinder, linkage and pin

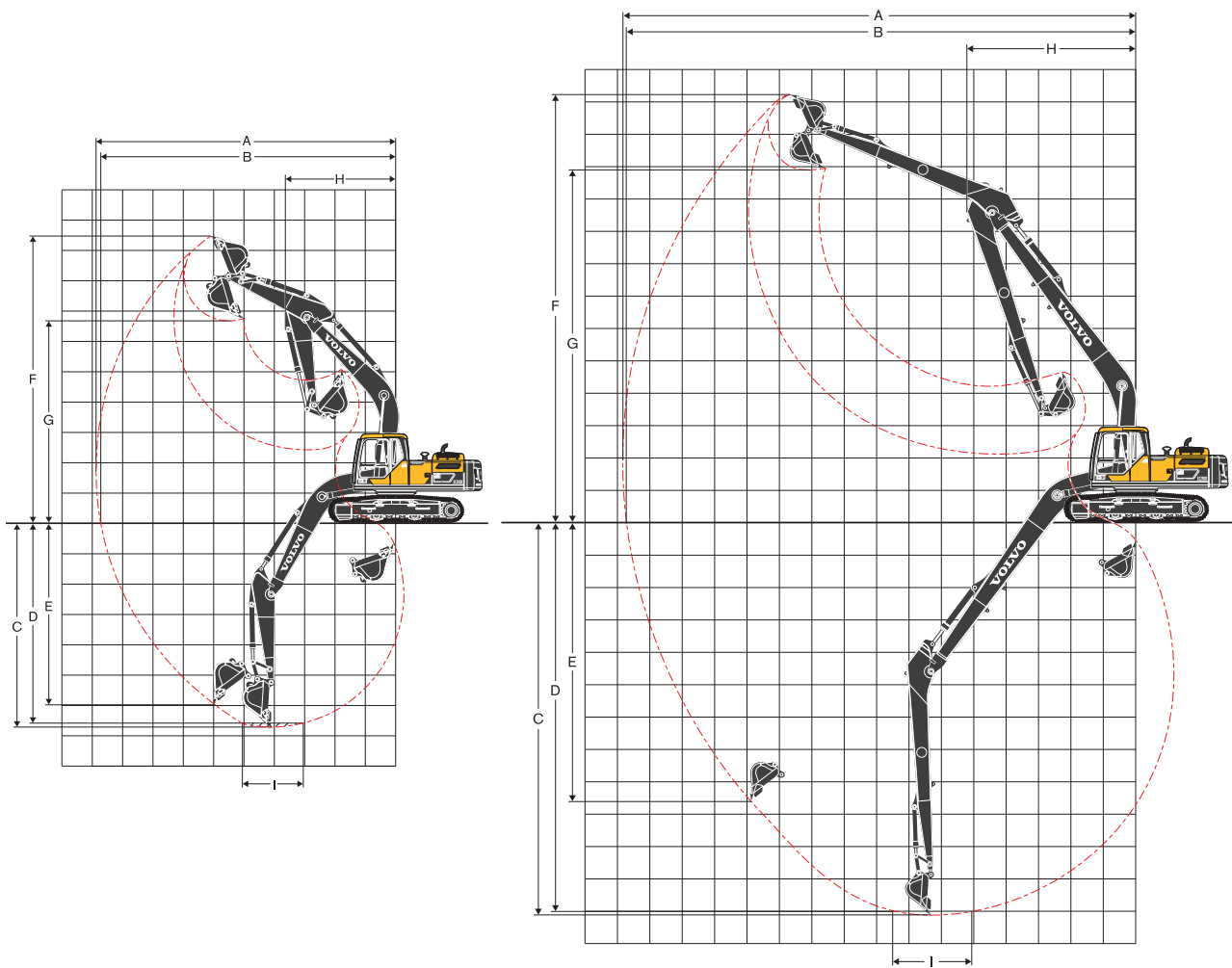

WORKING RANGES

Description	Unit	EC210D/EC210DL		EC210DLR
Boom	m	5.7	5.7	8.85
Arm	m	2.5	2.9	6.25
A Max. digging reach	mm	9 550	9 930	15 800
B Max. digging reach on ground	mm	9 380	9 770	15 700
C Max. digging depth	mm	6 330	6 730	12 100
D Max. digging depth (2.44 m level)	mm	6 100	6 540	12 000
E Max. vertical wall digging depth	mm	5 620	6 090	11 290
F Max. cutting height	mm	9 220	9 460	13 300
G Max. dumping height	mm	6 430	6 650	10 950
H Min. front swing radius	mm	3 670	3 640	5 200

DIGGING FORCES WITH DIRECT FIT BUCKET

Bucket radius		mm	1 470	1 470	1 248	
Breakout force - bucket	Normal	SAE J1179	kN	123	123	68
	Power boost	SAE J1179	kN	130	130	-
	Normal	ISO 6015	kN	136	136	77
	Power boost	ISO 6015	kN	144	144	-
Tearout force - dipper arm	Normal	SAE J1179	kN	112	96	44
	Power boost	SAE J1179	kN	118	102	-
	Normal	ISO 6015	kN	115	99	45
Power boost	ISO 6015	kN	122	105	-	
Rotation angle, bucket		°	175	175	178	

Specifications

LIFTING CAPACITY EC210D

Lifting capacity at the arm end without bucket.

For lifting capacity including bucket, simply subtract actual weight of the direct fit bucket or the bucket with quick coupler from the following values.

	Lifting hook related to ground level	1.5m		3.0m		4.5m		6.0m		7.5m		Max. reach		m		
		Along UC	Across UC	Along UC	Across UC	Along UC	Across UC	Along UC	Across UC	Along UC	Across UC	Along UC	Across UC			
Boom : 5.7m Arm : 2.5m Shoe : 600mm CWT : 3 700kg	7.5 m kg												*5 280	4 930	5.6	
	6.0 m kg							*5 120	4 440				*5 200	3 500	6.9	
	4.5 m kg					*6 520	*6 520	*5 600	4 270	4 560	2 950		*4 460	2 880	7.6	
	3.0 m kg					*8 380	6 110	6 320	4 020	4 460	2 860		4 040	2 570	8.0	
	1.5 m kg					9 430	5 620	6 060	3 780	4 340	2 750		3 890	2 460	8.1	
	0 m kg					9 170	5 400	5 880	3 630	4 260	2 670		3 980	2 500	7.9	
	-1.5 m kg			*10 270	*10 270	9 130	5 370	5 830	3 580				4 370	2 730	7.4	
	-3.0 m kg			*13 680	10 550	9 250	5 470	5 910	3 660				5 330	3 330	6.5	
-4.5 m kg			*10 530	*10 530	*7 520	5 760						*6 610	5 040	5.0		
Boom : 5.7m Arm : 2.9m Shoe : 600mm CWT : 3 700kg	7.5 m kg							*4 790	4 500				*4 630	4 260	6.2	
	6.0 m kg							*4 700	4 500				*4 310	3 160	7.3	
	4.5 m kg							*5 230	4 320	4 600	2 980		4 110	2 640	8.0	
	3.0 m kg					*7 810	6 220	*6 080	4 060	4 480	2 870		3 740	2 380	8.4	
	1.5 m kg					9 500	5 680	6 080	3 800	4 340	2 740		3 610	2 270	8.5	
	0 m kg					9 160	5 380	5 870	3 610	4 230	2 640		3 680	2 300	8.3	
	-1.5 m kg		*5 910	*5 910	*9 760	*9 760	9 070	5 310	5 780	3 530	4 200	2 610		3 990	2 490	7.8
	-3.0 m kg		*10 760	*10 760	*14 440	10 360	9 150	5 370	5 820	3 570				4 750	2 960	6.9
-4.5 m kg			*11 710	10 760	*8 320	5 600							*6 350	4 170	5.6	
Boom : 5.7m Arm : 2.5m Shoe : 600mm CWT : 4 200kg	7.5 m kg							*5 120	4 720				*5 200	5 240	5.6	
	6.0 m kg							*5 120	4 720				*5 200	3 750	6.9	
	4.5 m kg					*6 520	*6 520	*5 600	4 560	4 830	3 170		4 730	3 100	7.6	
	3.0 m kg					*8 380	6 530	*6 410	4 310	4 730	3 080		4 290	2 780	8.0	
	1.5 m kg					9 980	6 040	6 420	4 070	4 610	2 960		4 130	2 660	8.1	
	0 m kg					9 720	5 810	6 250	3 920	4 530	2 890		4 230	2 700	7.9	
	-1.5 m kg			*10 270	*10 270	9 690	5 780	6 190	3 870				4 650	2 960	7.4	
	-3.0 m kg			*13 680	11 320	*9 790	5 890	6 280	3 940				5 660	3 590	6.5	
-4.5 m kg			*10 530	*10 530	*7 520	6 180						*6 610	5 400	5.0		
Boom : 5.7m Arm : 2.9m Shoe : 600mm CWT : 4 200kg	7.5 m kg							*4 790	4 790				*4 630	4 540	6.2	
	6.0 m kg							*4 700	*4 700				*4 310	3 390	7.3	
	4.5 m kg							*5 230	4 610	4 870	3 200		*4 260	2 840	8.0	
	3.0 m kg					*7 810	6 640	*6 080	4 350	4 750	3 080		3 980	2 570	8.4	
	1.5 m kg					*9 570	6 090	6 440	4 080	4 610	2 960		3 840	2 460	8.5	
	0 m kg					9 720	5 800	6 230	3 900	4 500	2 860		3 920	2 490	8.3	
	-1.5 m kg		*5 910	*5 910	*9 760	*9 760	9 620	5 720	6 150	3 820	4 470	2 830		4 250	2 700	7.8
	-3.0 m kg		*10 760	*10 760	*14 440	11 120	9 700	5 790	6 190	3 860				5 050	3 200	6.9
-4.5 m kg			*11 710	11 520	*8 320	6 020							*6 350	4 480	5.6	

Notes: 1. Machine in "Fine Mode-F" (Power Boost) for lifting capacities. 2. The above loads are in compliance with SAE J1097 and ISO 10567 Hydraulic Excavator Lifting Capacity Standards.

3. Rated loads do not exceed 87% of hydraulic lifting capacity or 75% of tipping load. 4. Rated loads marked with an asterisk (*) are limited by hydraulic capacity rather than tipping load.

LIFTING CAPACITY EC210DL

Lifting capacity at the arm end without bucket.

For lifting capacity including bucket, simply subtract actual weight of the direct fit bucket or the bucket with quick coupler from the following values.

	Lifting hook related to ground level	1.5m		3.0m		4.5m		6.0m		7.5m		Max. reach		m		
		Along UC	Across UC	Along UC	Across UC	Along UC	Across UC	Along UC	Across UC	Along UC	Across UC	Along UC	Across UC			
Boom : 5.7m Arm : 2.5m Shoe : 600mm CWT : 3 700kg	7.5 m kg												*5 280	*5 280	5.6	
	6.0 m kg							*5 120	4 920				*5 200	3 900	6.9	
	4.5 m kg					*6 520	*6 520	*5 600	4 750	5 160	3 290		*5 050	3 220	7.6	
	3.0 m kg					*8 380	6 870	*6 410	4 500	5 060	3 200		4 580	2 890	8.0	
	1.5 m kg					*10 010	6 360	6 920	4 250	4 940	3 090		4 420	2 760	8.1	
	0 m kg					10 690	6 130	6 750	4 100	4 850	3 010		4 530	2 820	7.9	
	-1.5 m kg			*10 270	*10 270	*10 650	6 100	6 690	4 050				4 980	3 080	7.4	
	-3.0 m kg			*13 680	12 220	*9 790	6 210	6 780	4 120				6 090	3 750	6.5	
-4.5 m kg			*10 530	*10 530	*7 520	6 510						*6 610	5 670	5.0		
Boom : 5.7m Arm : 2.9m Shoe : 600mm CWT : 3 700kg	7.5 m kg							*4 790	*4 790				*4 630	*4 630	6.2	
	6.0 m kg							*4 700	*4 700				*4 310	3 520	7.3	
	4.5 m kg							*5 230	4 800	4 930	3 320		*4 260	2 960	8.0	
	3.0 m kg					*7 810	6 980	*6 080	4 530	5 080	3 210		4 240	2 670	8.4	
	1.5 m kg					*9 570	6 420	6 950	4 270	4 930	3 080		4 100	2 560	8.5	
	0 m kg					*10 550	6 120	6 730	4 080	4 830	2 980		4 190	2 600	8.3	
	-1.5 m kg		*5 910	*5 910	*9 760	*9 760	10 590	6 040	6 640	4 000	4 790	2 950		4 550	2 810	7.8
	-3.0 m kg		*10 760	*10 760	*14 440	12 010	*10 070	6 110	6 690	4 040				5 420	3 340	6.9
-4.5 m kg			*11 710	*11 710	*8 320	6 350							*6 350	4 690	5.6	
Boom : 5.7m Arm : 2.5m Shoe : 600mm CWT : 4 200kg	7.5 m kg							*5 120	*5 120				*5 200	*5 200	5.6	
	6.0 m kg							*5 120	*5 120				*5 200	4 150	6.9	
	4.5 m kg					*6 520	*6 520	*5 600	5 050	*5 270	3 520		*5 280	3 440	7.6	
	3.0 m kg					*8 380	7 310	*6 410	4 800	5 350	3 430		4 840	3 100	8.0	
	1.5 m kg					*10 010	6 800	*7 240	4 550	5 220	3 310		4 680	2 970	8.1	
	0 m kg					*10 730	6 570	7 130	4 400	5 140	3 240		4 800	3 030	7.9	
	-1.5 m kg			*10 270	*10 270	*10 650	6 540	7 080	4 350				5 270	3 320	7.4	
	-3.0 m kg			*13 680	13 040	*9 790	6 650	7 170	4 420				6 440	4 020	6.5	
-4.5 m kg			*10 530	*10 530	*7 520	6 950						*6 610	6 060	5.0		
Boom : 5.7m Arm : 2.9m Shoe : 600mm CWT : 4 200kg	7.5 m kg							*4 790	*4 790				*4 630	*4 630	6.2	
	6.0 m kg							*4 700	*4 700				*4 310	3 750	7.3	
	4.5 m kg							*5 230	5 100	4 930	3 550		*4 260	3 170	8.0	
	3.0 m kg					*7 810	7 430	*6 080	4 830	*5 300	3 440		*4 370	2 870	8.4	
	1.5 m kg					*9 570	6 860	*6 970	4 570	5 220	3 310		4 350	2 760	8.5	
	0 m kg					*10 550	6 560	7 120	4 380	5 110	3 210		4 440	2 800	8.3	
	-1.5 m kg		*5 910	*5 910	*9 760	*9 760	*10 690	6 480	7 030	4 300	5 080	3 180		4 830	3 030	7.8
	-3.0 m kg		*10 760	*10 760	*14 440	12 840	*10 070	6 550	7 080	4 340				5 740	3 590	6.9
-4.5 m kg			*11 710	*11 710	*8 320	6 790							*6 350	5 020	5.6	

Notes: 1. Machine in "Fine Mode-F" (Power Boost) for lifting capacities. 2. The above loads are in compliance with SAE J1097 and ISO 10567 Hydraulic Excavator Lifting Capacity Standards.

3. Rated loads do not exceed 87% of hydraulic lifting capacity or 75% of tipping load. 4. Rated loads marked with an asterisk (*) are limited by hydraulic capacity rather than tipping load.

LIFTING CAPACITY EC210DLR

Lifting capacity at the arm end without bucket.

For lifting capacity including bucket, simply subtract actual weight of the direct fit bucket or the bucket with quick coupler from the following values.

Lifting hook related to ground level	1.5m		3.0m		4.5m		6.0m		7.5m	
	Along UC	Across UC	Along UC	Across UC	Along UC	Across UC	Along UC	Across UC	Along UC	Across UC
3.0 m kg					*4 080	*4 080	*2 920	*2 920	*2 320	*2 320
1.5 m kg					*5 180	*5 180	*3 520	*3 520	*2 680	*2 680
0 m kg			*1 710	*1 710	*4 080	*4 080	*4 000	*4 000	*3 010	3 000
-1.5 m kg	*1 840	*1 840	*2 380	*2 380	*4 090	*4 090	*4 310	3 780	*3 250	2 800
-3.0 m kg	*2 530	*2 530	*3 120	*3 120	*4 610	*4 610	*4 460	3 650	*3 400	2 680
-4.5 m kg	*3 260	*3 260	*3 930	*3 930	*5 410	*5 410	*4 470	3 620	*3 450	2 630
-6.0 m kg	*4 040	*4 040	*4 830	*4 830	*5 820	5 680	*4 340	3 660	*3 390	2 640
-7.5 m kg	*4 880	*4 880	*5 850	*5 850	*5 320	*5 320	*4 030	3 770	*3 180	2 710
-9.0 m kg			*6350	*6 350	*4 560	*4 560	*3 510	*3 510	*2 760	*2 760
-10.5 m kg					*3 360	*3 360	*2 600	*2 600	*1 930	*1 930

Lifting hook related to ground level	9.0m		10.5m		12.0m		13.0m		Max. reach		
	Along UC	Across UC	Along UC	Across UC	Along UC	Across UC	Along UC	Across UC	Along UC	Across UC	m
12.0 m kg									*510	*510	10.3
10.5 m kg									*450	*450	11.6
9.0 m kg					*940	*940			*420	*420	12.6
7.5 m kg			*1 330	*1 330	*1 310	*1 310			*410	*410	13.4
6.0 m kg			*1 430	*1 430	*1 370	*1 370	*850	*850	*400	*400	13.9
4.5 m kg	*1 720	*1 720	*1 560	*1 560	*1 450	*1 450	*1 210	*1 210	*410	*410	14.3
3.0 m kg	*1 950	*1 950	*1 720	*1 720	*1 560	*1 560	*1 450	1 290	*430	*430	14.5
1.5 m kg	*2 200	*2 200	*1 880	*1 880	*1 670	1 550	*1 520	1 230	*460	*460	14.6
0 m kg	*2 420	2 320	*2 040	1 830	*1 780	1 460	*1 590	1 170	*510	*510	14.4
-1.5 m kg	*2 600	2 170	*2 170	1 730	*1 870	1 390	*1 600	1 130	*580	*580	14.2
-3.0 m kg	*2 720	2 080	*2 260	1 650	*1 920	1 350	*1 100	*1 100	*670	*670	13.7
-4.5 m kg	*2 770	2 030	*2 290	1 620	*1 930	1 330			*810	*810	13.1
-6.0 m kg	*2 730	2 030	*2 240	1 630	*1 650	1 360			*1 020	*1 020	12.3
-7.5 m kg	*2 550	2 090	*2 050	1 700					*1 370	*1 370	11.2
-9.0 m kg	*2 160	*2 160							*1 890	*1 890	9.7
-10.5 m kg									*1 860	*1 860	7.6

Notes: 1. Machine in "Fine Mode-F" (Power Boost) for lifting capacities. 2. The above loads are in compliance with SAE J1097 and ISO 10567 Hydraulic Excavator Lifting Capacity Standards. 3. Rated loads do not exceed 87% of hydraulic lifting capacity or 75% of tipping load. 4. Rated loads marked with an asterisk (*) are limited by hydraulic capacity rather than tipping load.

Equipment

STANDARD EQUIPMENT

Engine

Turbocharged, 4 stroke diesel engine with water cooling, direct injection and charged air cooler

Air filter with indicator

Air intake heater

Cyclone pre-cleaner

Fuel filter and water separator

Extra water separator

Alternator, 80 A

Electric/Electronic control system

Contronics

Advanced mode control system

Self-diagnostic system

Machine status indication

Engine speed sensing power control

Automatic idling system

One-touch power boost

Power max mode (P)

Safety stop/start function

Adjustable LCD color monitor

Master electrical disconnect switch

Engine restart prevention circuit

High capacity halogen lights:

Frame-mounted 2

Boom-mounted 1

Batteries, 2 x 12 V / 150 Ah

Start motor, 24 V / 5.5 kW

Hydraulic system

Automatic sensing hydraulic system

Summation system

Boom priority

Arm priority

Swing priority

Boom and arm regeneration valves

ECO mode fuel saving technology

Swing anti-rebound valves

Boom and arm holding valves

Multi-stage filtering system

Cylinder cushioning

Cylinder contamination seals

Automatic two-speed travel motors

Hydraulic oil, ISO VG 68

Superstructure

Counterweight: 3 700kg

Access way with handrail

Tool storage area

Punched metal anti-slip plates

Undercovers

Rear view mirror on counterweight

Cab and interior

Cab with roof hatch

Control lock out lever

Travel pedals and hand levers

Adjustable operator seat and joystick control console

Semi-long control joysticks

Heater & air conditioner, manual

Flexible antenna

Radio with USB input

Cab, all-weather sound suppressed, includes:

Cup holders

Door locks

Tinted glass

Floor mat

Horn

Large storage area

Pull-up type front window

Removable lower windshield

Seat belt

Safety glass

Windshield wiper with intermittent feature

Master key

Undercarriage

Undercover

Hydraulic track adjusters

Greased and sealed track link

Track guard

600 mm with triple grousers

Digging equipment

Boom: 5.7 m mono

Arm: 2.9 m

Linkage

Service

Tool kit, daily maintenance

Spare parts kit

OPTIONAL EQUIPMENT

Engine

- Rain cap or Oil bath pre-cleaner
- Block heater: 240 V
- Water separator with heater
- Fuel filler pump: 35 l/min or 50 l/min with auto stop

Electric

- Extra work lights:
 - Boom-mounted 1
 - Cab-mounted 3
 - Counterweight-mounted 1
- Travel alarm
- Anti-theft with code lock system
- Rotating warning beacon

Hydraulic system

- Boom hose rupture valve (HRV) with overload warning device
- Hydraulic piping:
 - Breaker & shear, 1 or 2 pump flow
 - Quick coupler piping
- Additional return filter for breaker and shear
- Hydraulic oil, ISO VG 32, 46
- Hydraulic oil, longlife oil 32, 46, 68

Cab and interior

- Heater & air conditioner, automatic
- Electric pedal for breaker and shear
- Control joysticks (4 switches, 3 switch & proportional)
- Cab-mounted falling object guard (FOG)
- Cab-mounted falling object protective structure (FOPS)
- Sun screens, front, roof, rear
- Rain shield
- Rear view camera
- Ashtray and lighter
- Safety net for front window
- Specific key

Superstructure

- Counterweight: 4 200kg, 4 900kg

Undercarriage

- Full track guard
 - 500 / 600 / 700 / 800 / 900 mm with triple grousers
 - 600 mm HD with triple grousers
 - 700 mm with double grousers

Digging equipment

- Arm: 2.5m, 6.25m long reach
- Boom: 8.85 m long reach
- Linkage with lifting eye

Service

- Tool kit, full scale
-

SELECTION OF VOLVO OPTIONAL EQUIPMENT

Rear view camera**Oilbath pre-cleaner****FOPS****Fuel Filler Pump****Boom & arm configuration****Full trackguard**

Not all products are available in all markets. Under our policy of continuous improvement, we reserve the right to change specifications and design without prior notice. The illustrations do not necessarily show the standard version of the machine.

VOLVO

Volvo Construction Equipment

www.volvoce.com